

# SANLIURFA INSTALLATION INSTRUCTIONS

## LT VERSION

**Important: See separate instructions for the installation of the support structures middle posts/columns**

**Ignore the installation of the posts as shown in the directions below**

**Ignore the angled guides and assume instead the guides are curved**



*All weather protection systems!*

**RETRACTABLE**  
**AWNINGS.COM**

**All information contained in this document was provided by the manufacturer of the components for this particular model. As a fabricator/distributor, Retractableawnings.com Inc. claims no liability with respect to these documents as we are not engineers and did not complete any of the information, engineering or calculations in this document.**

**All measurements in this document are metric. To convert from metric (meters, centimeters and millimeters) to imperial (feet and inches) visit this website:**

**[http://www.onlineconversion.com/length\\_common.htm](http://www.onlineconversion.com/length_common.htm)**

IA = Interaxis between conveyor rafter bars

One Module

200 cm > 450 cm

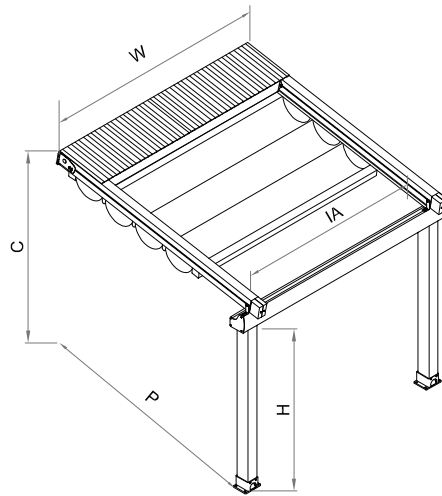

Two Module

450 cm > 900 cm

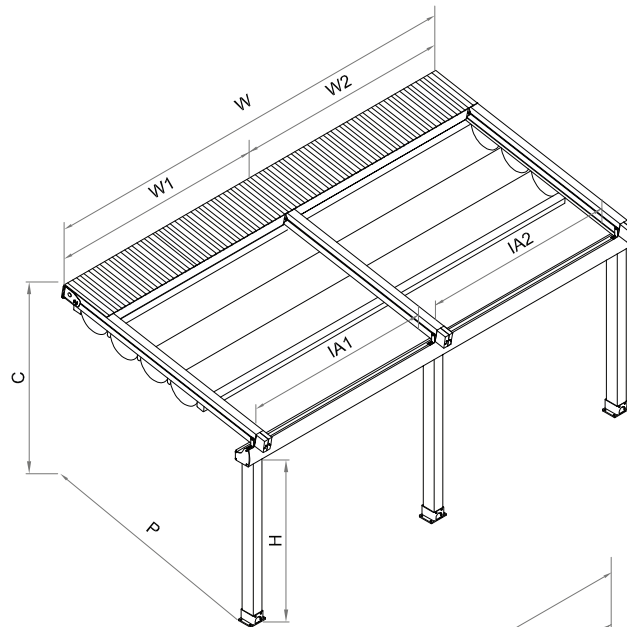

Three Module

900 cm > 1300 cm

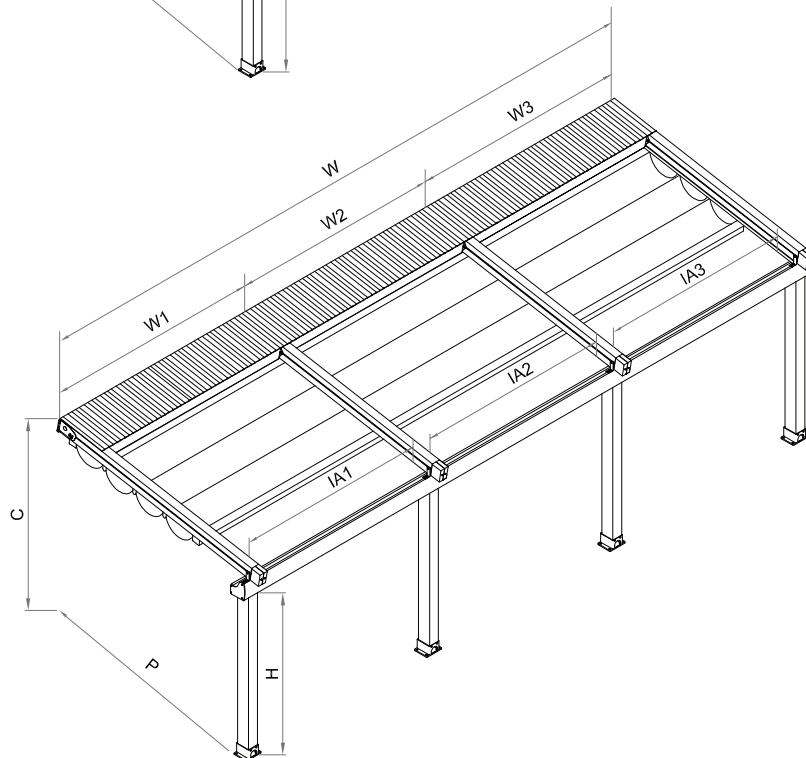

## STEP I

Install wall brackets using suitable fixings for site requirements. Ensure all wall brackets are same level with each other and correct width apart to match the conveyor rafters on your system.

Note : The tolerance value for " W1,W2,W3" is ( + 20 mm , -20 mm )

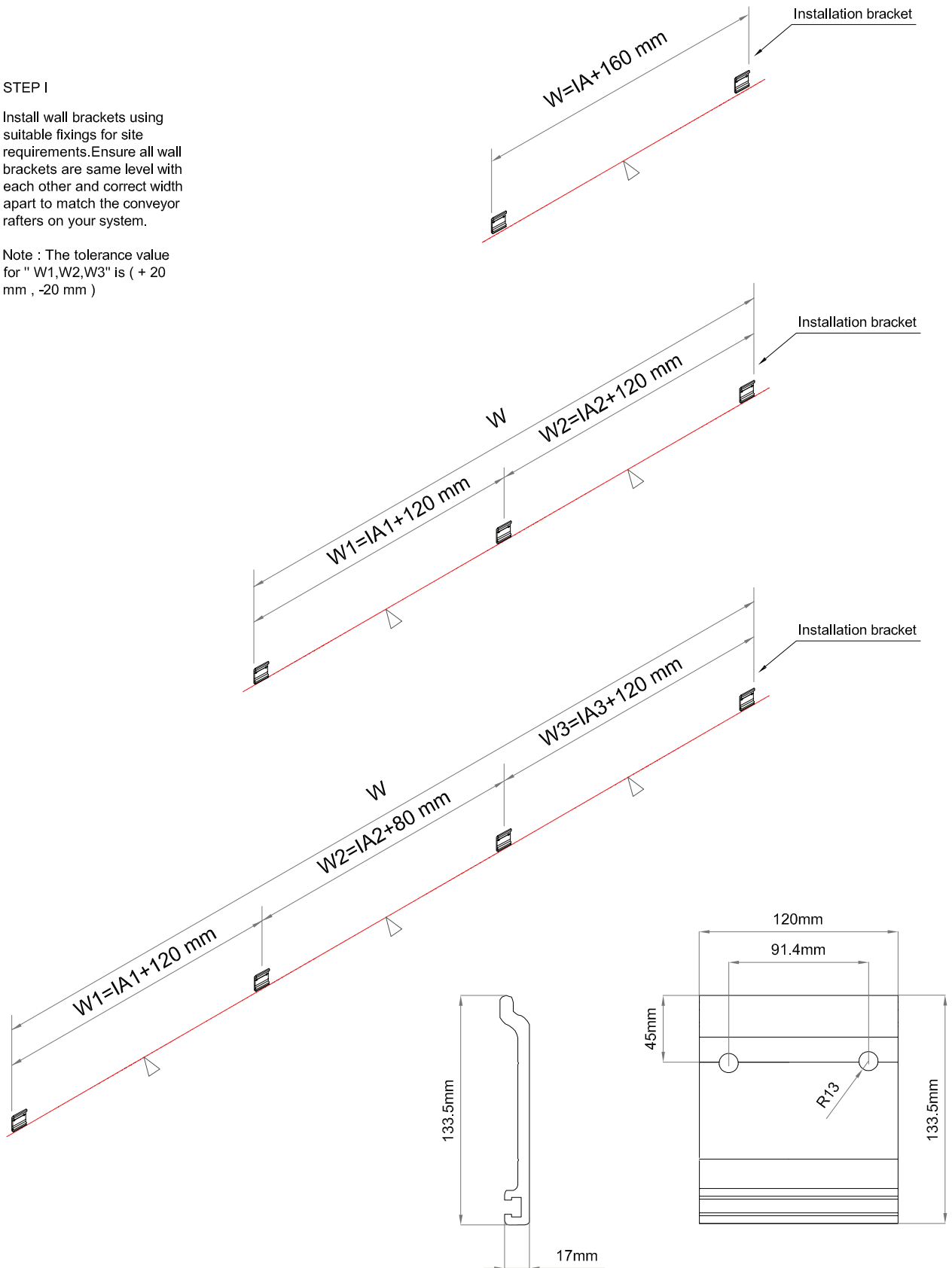

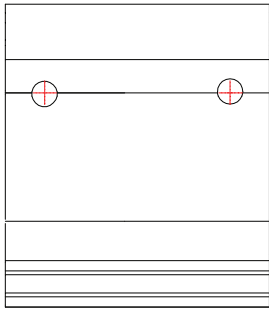

Sign the holes



Drill the holes by  $\varnothing 17$   
depth 100 mm



Drill the holes by  $\varnothing 17$   
depth 100 mm

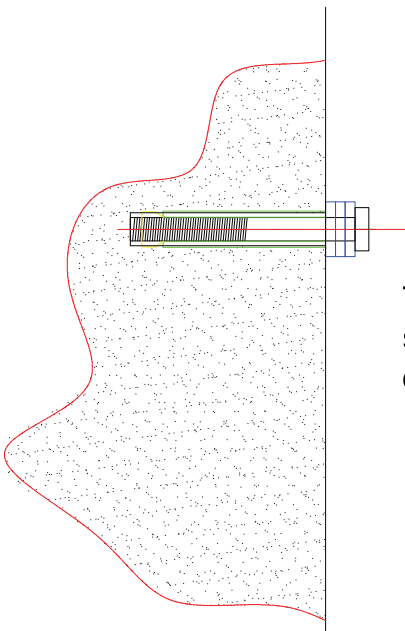

Tighten the M12 x 100  
steel bolts clockwise  
direction by  $\varnothing 19$  wrench

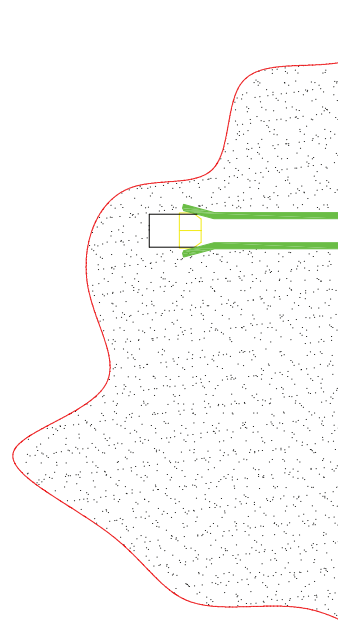

**NOTE: The instructions say steel bolts. The installer needs to determine which fastener type to use based on the substrate (wood, steel, brick, CMU etc.) along with local building code requirements (if any).**

Extract the M12 x 100  
steel bolts

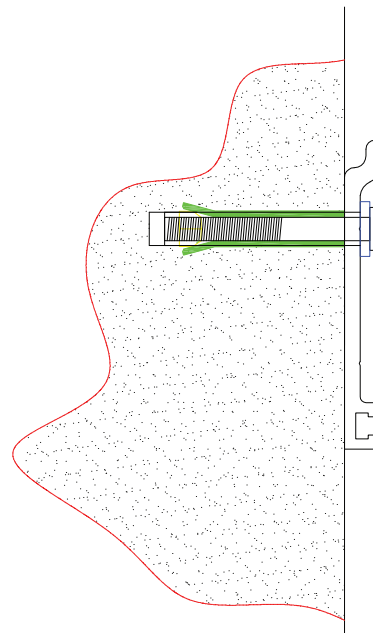

Tighten the steel bolts  
with installation brackets

STEP II

Establishment of front columns & front rafter bar (gutter)

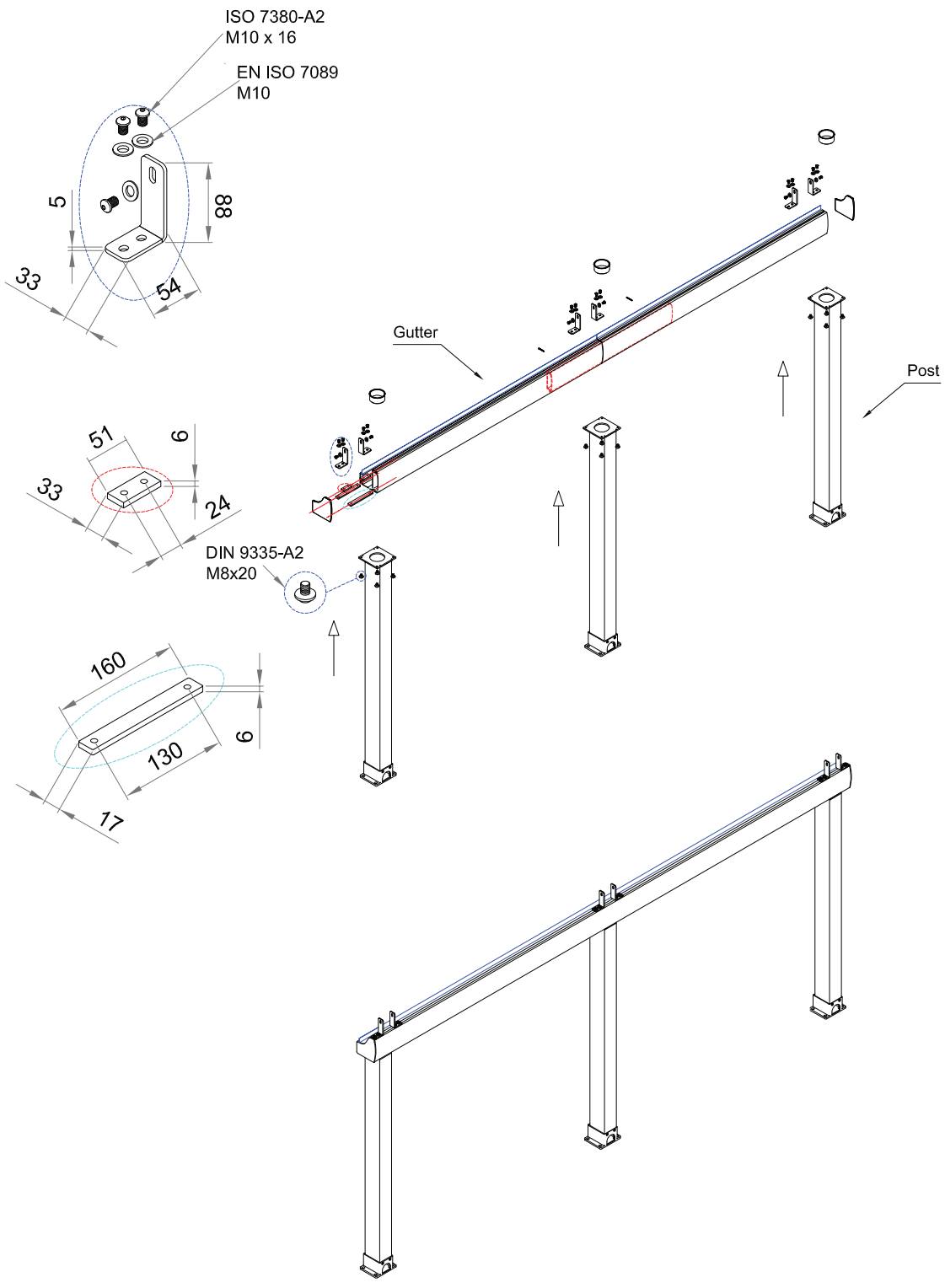

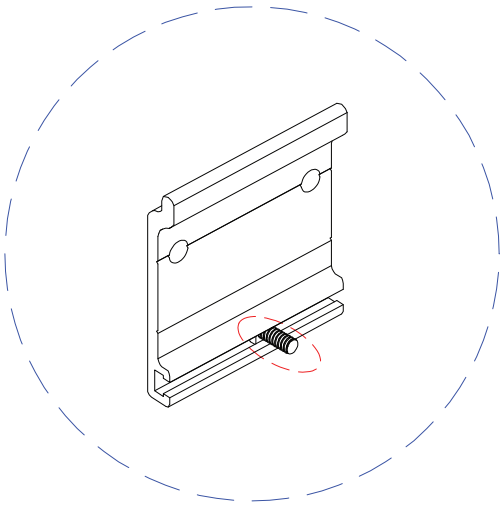

M8 x 20.5

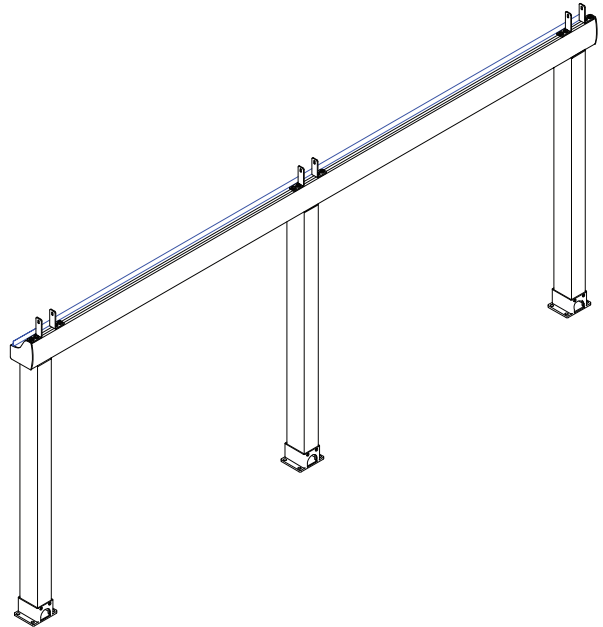
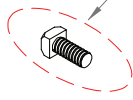

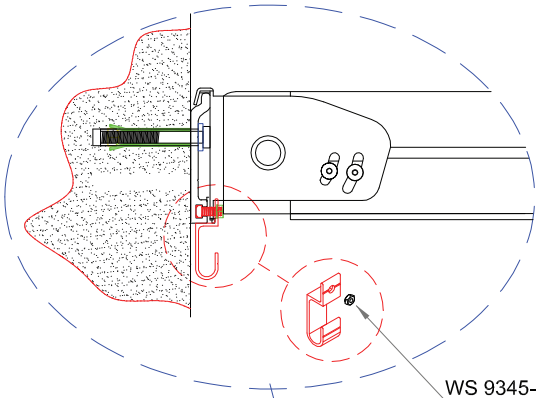

WS 9345-A2  
M8

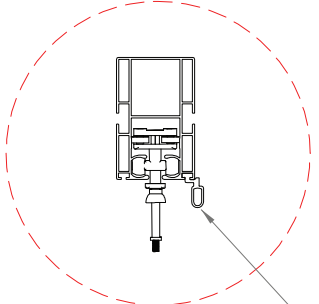
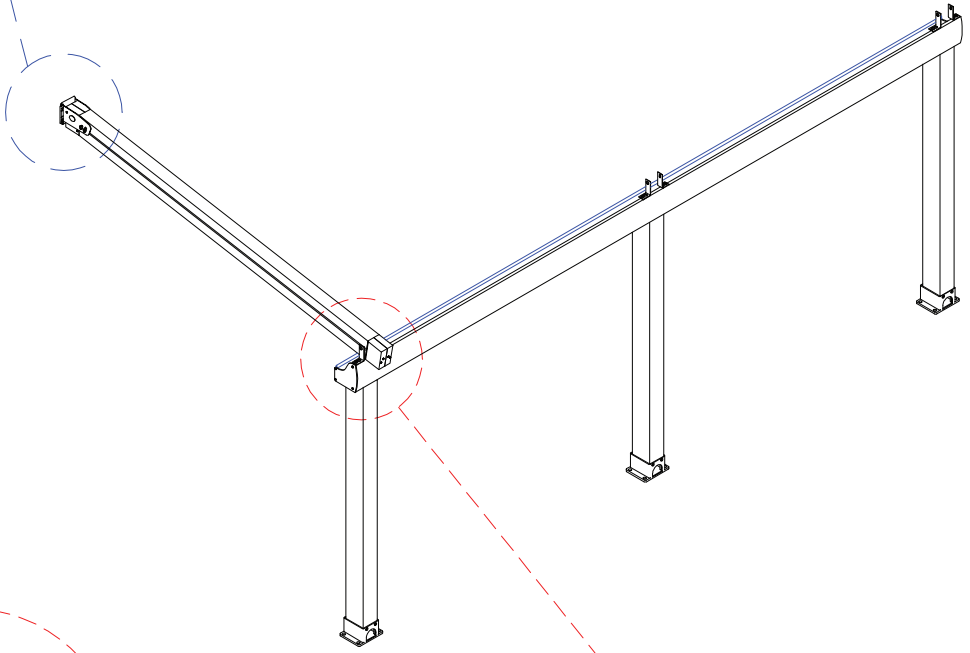

Cord on right hand side

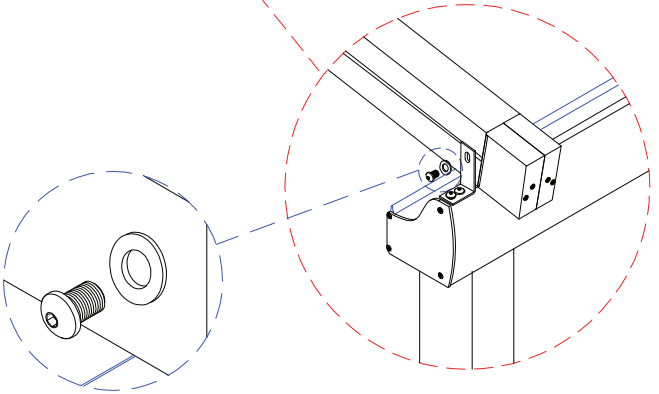

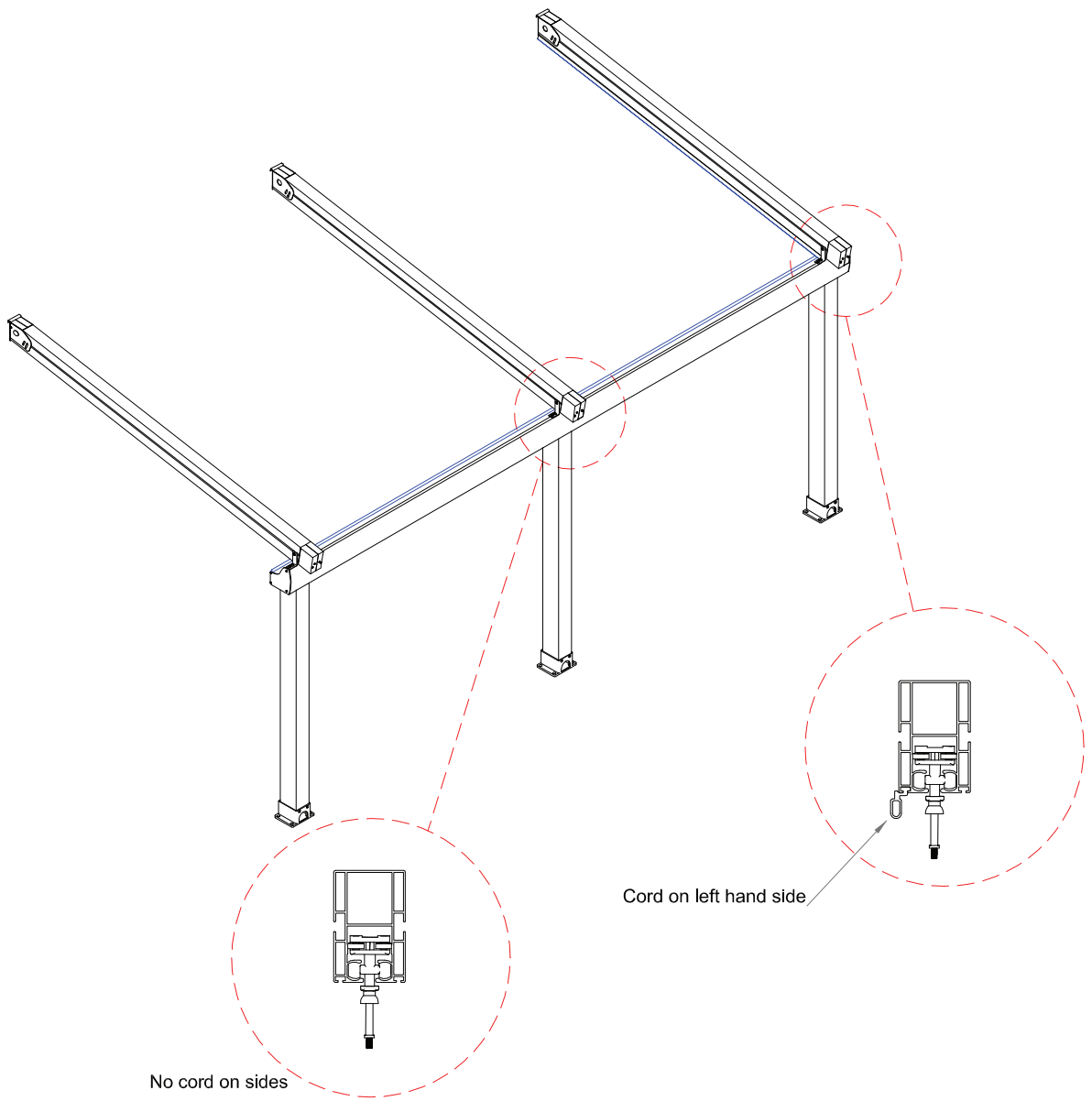



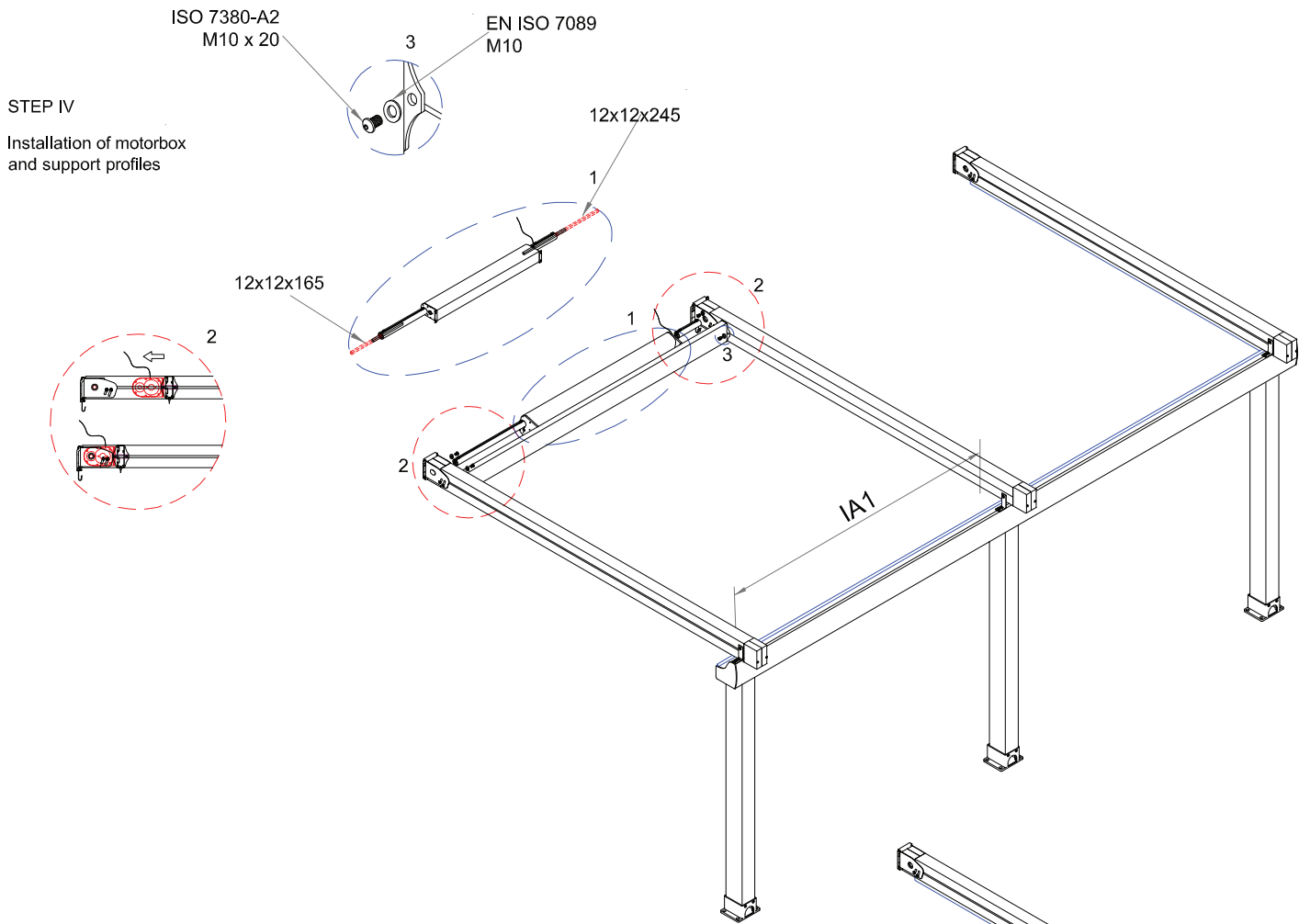

STEP V  
Setting the rectangularity

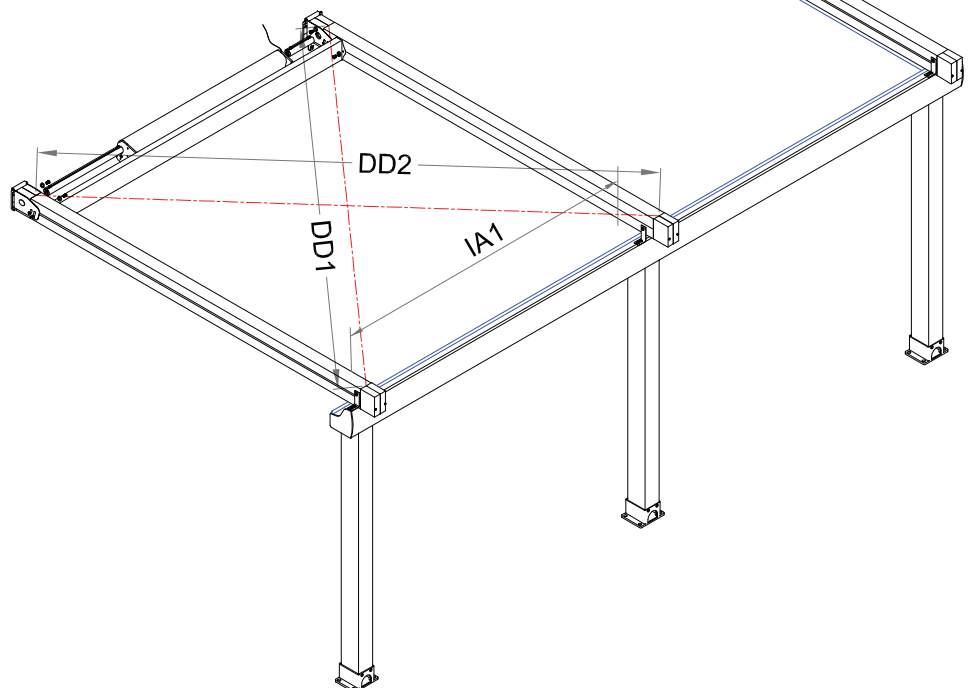

Possibility1

DD1=DD2 ⇒ OK

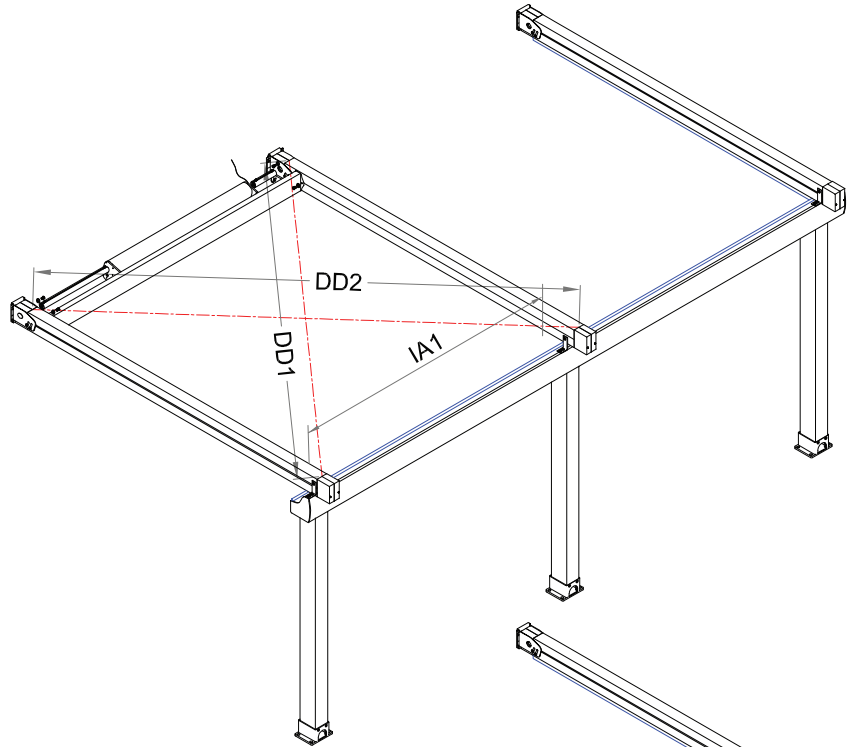

Possibility1

DD1>DD2 ⇒ Move front side  
to right hand side  
until DD1=DD2

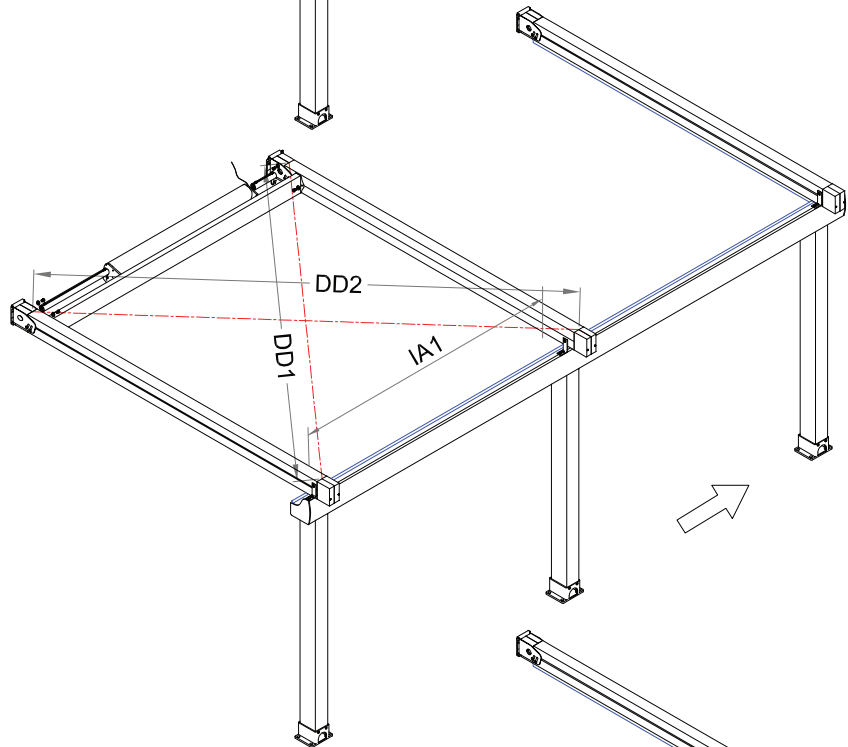

Possibility1

DD1<DD2 ⇒ Move front side  
to left hand side  
until DD1=DD2

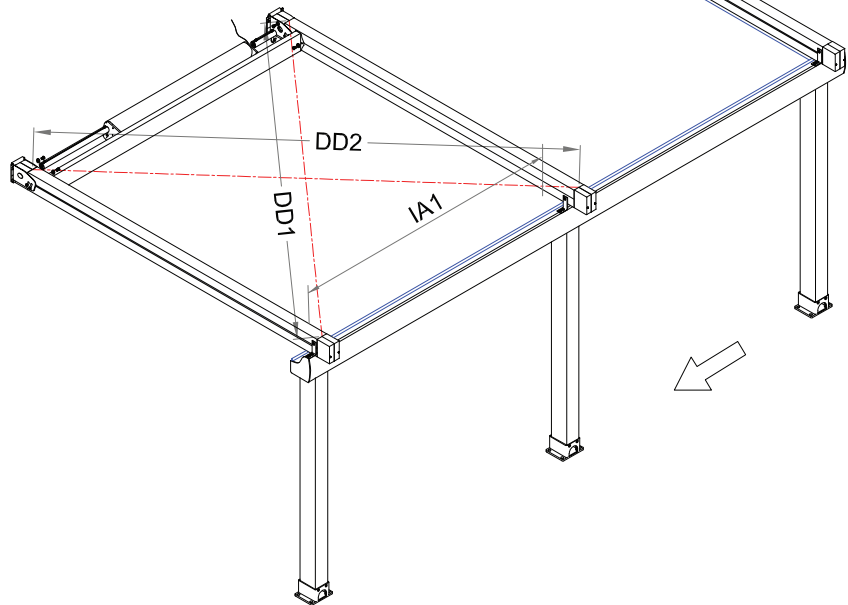

## STEP VI

Installation of top cover support profiles

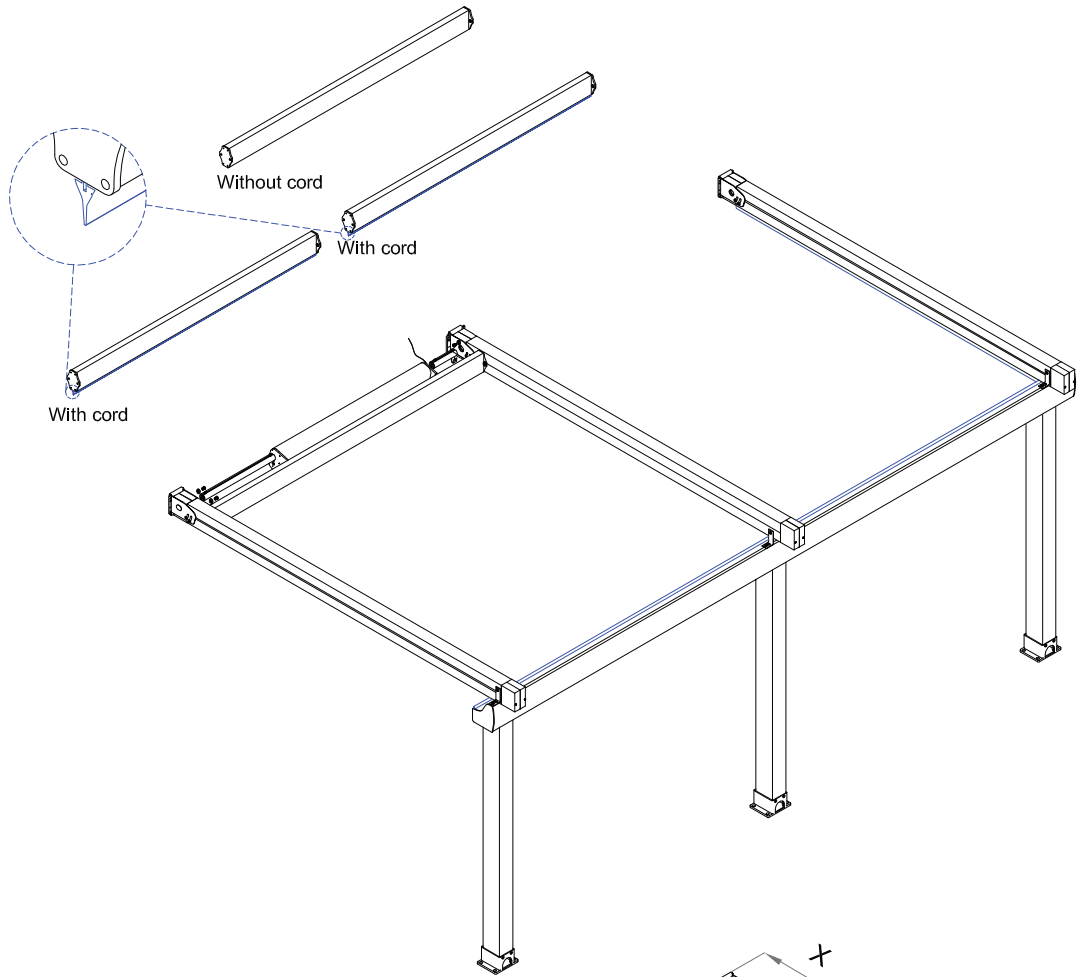
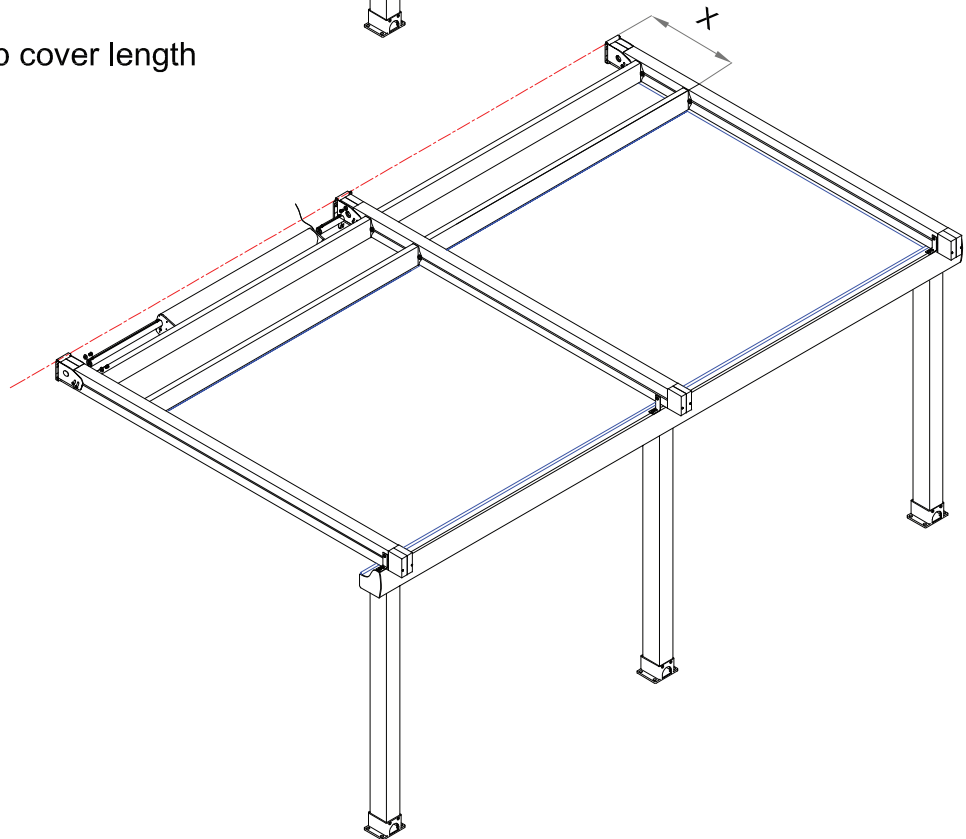
 $X =$  Top cover length

## STEP VII

Installation of square pins  
and transmission bar

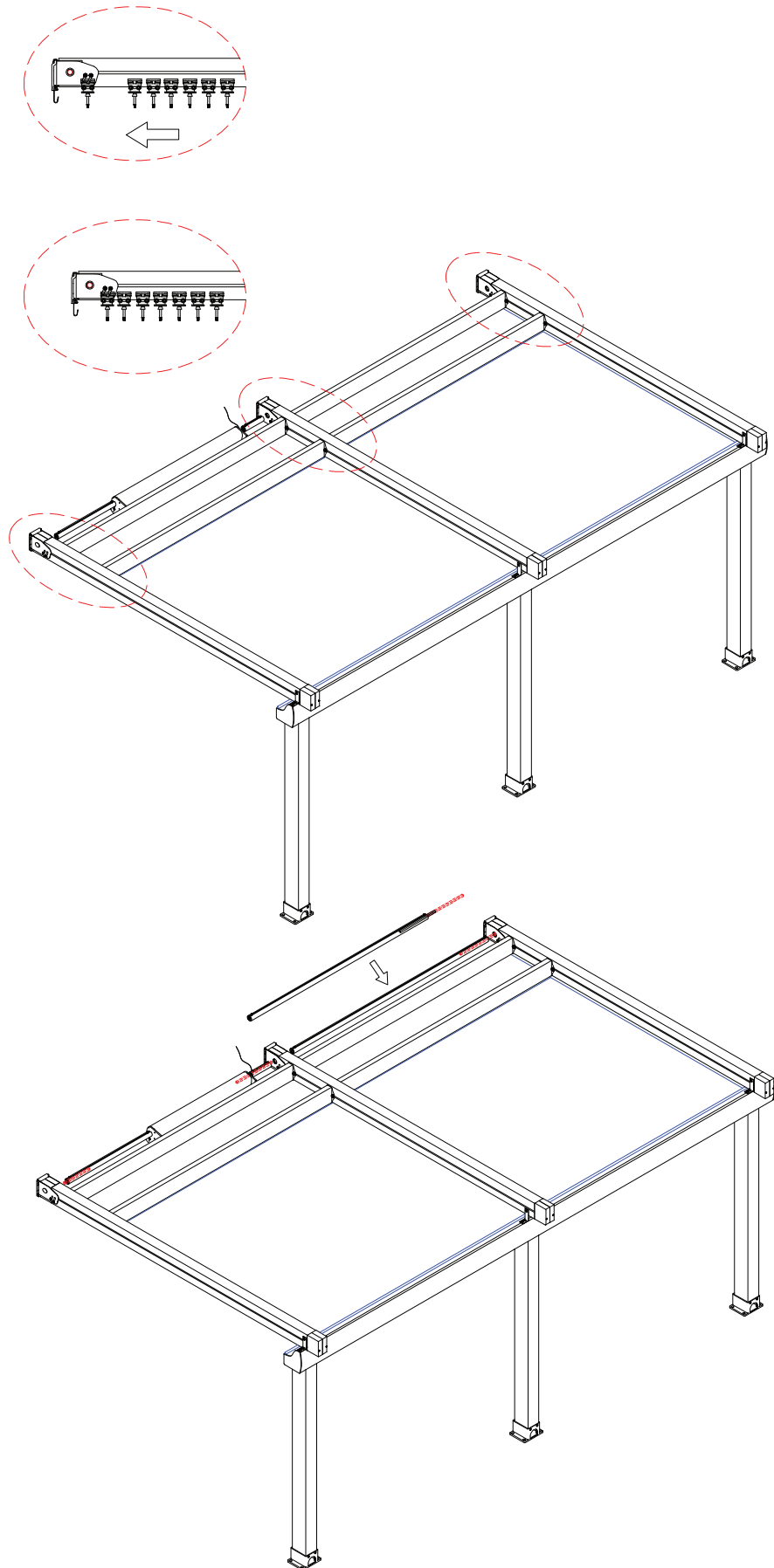

Drive the square pins to the directions mentioned below on details A,B,C.

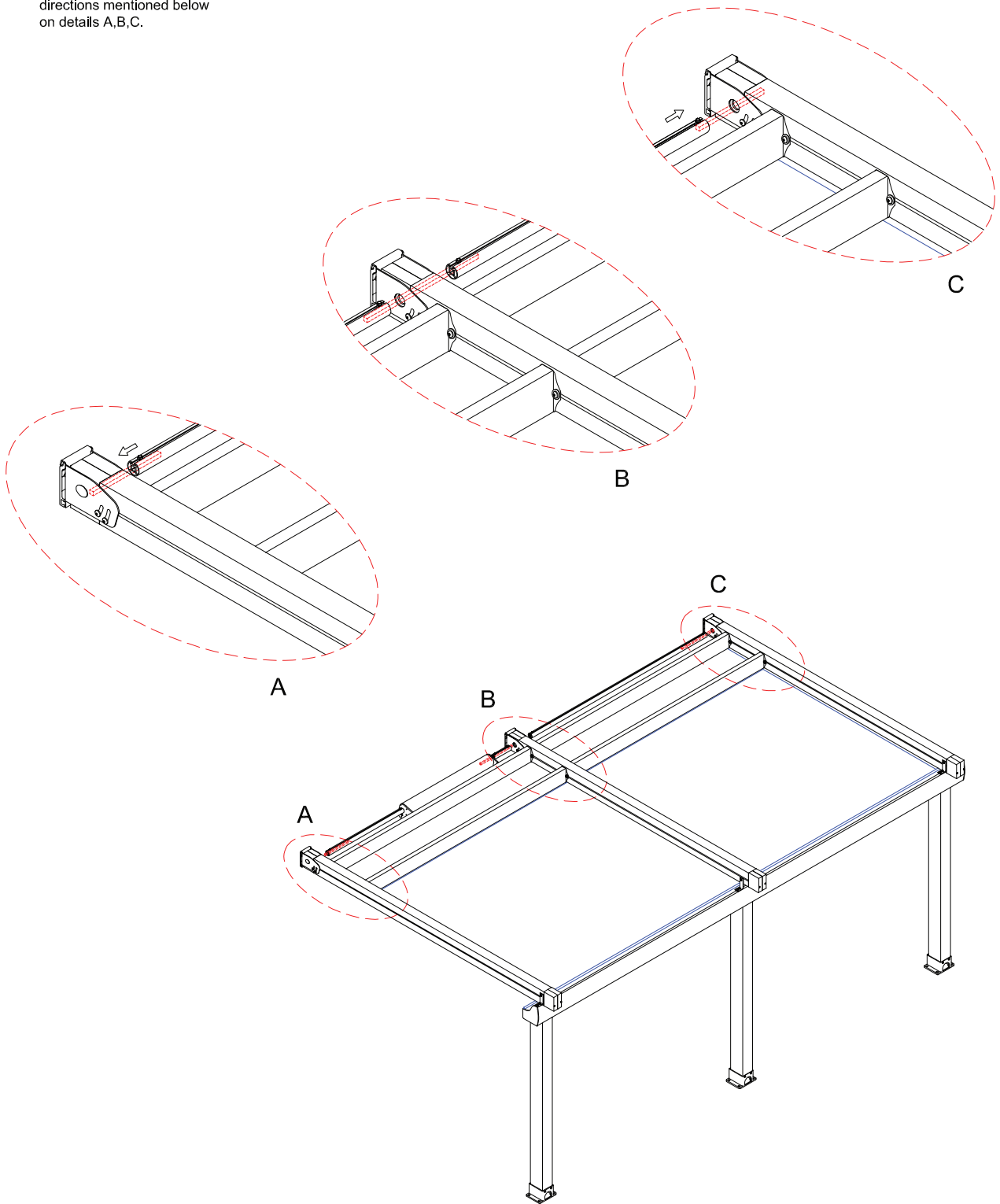

## STEP VIII

## Installation of fabric

Take care to match the fabric front right position (which writes on the package of fabric) and structure front right position to install the fabric on the system and start the installation from the front sliders.

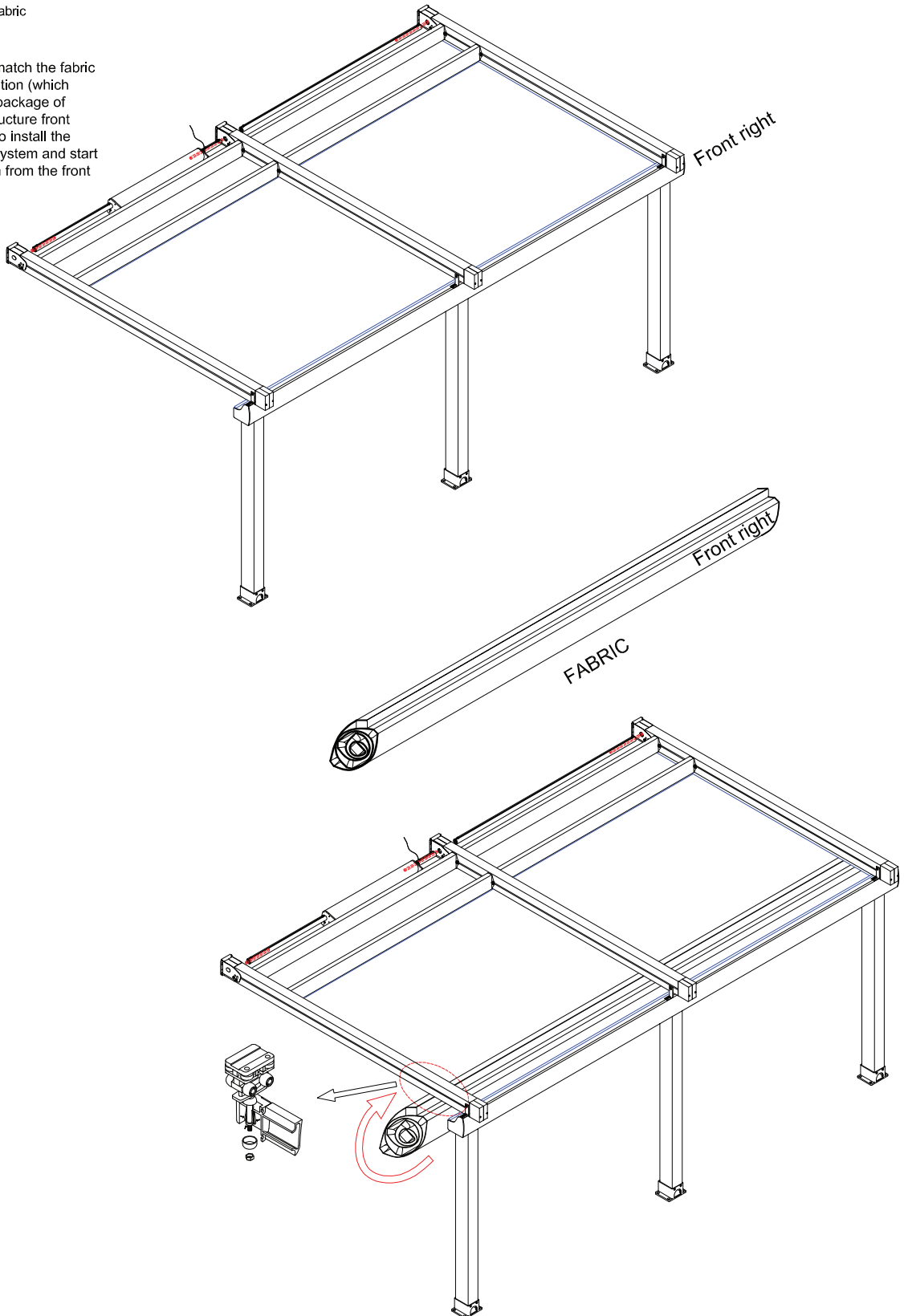

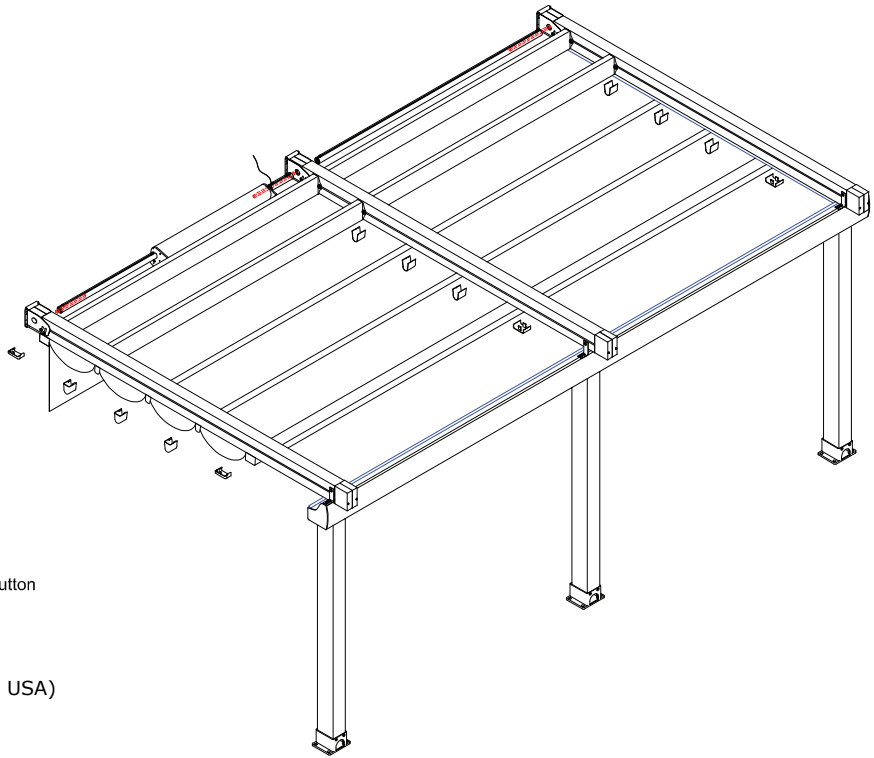

## STEP IX

### Programming RTS Somfy motor

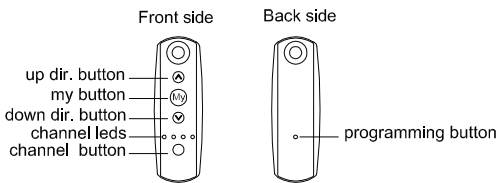

Step1:  
 Connect the motorbox to 220 AC power (110v in the USA)  
 -Blue : Notr  
 -Brown:Phase  
 -Green-Yellow:Ground

Step2:



Check the channel for programming motor.Pres the channel button to select the channel 1 , make the channel 1 led light flashing.

Step3:

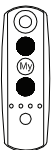

Press the up and down button at same instance motor will give a click.(this means motor and remote control unit is introduced to each other.

Step4:



Press the up button to check the direction of movement.If the fabric moves to up direction go on to step 6, if no go on to step 5.

Step5:



Press the My button until the motorbox gives a click.The direction is reversed

Step6:



Move the fabric to back limit position that the fabric is totally gathered under the front top cover support profile.

Step7:



Press the My button & Down Dir. Button at the same instance for once the fabric will start to move down direction.And stop the movement with My button appr. 5 cm before the front en limit.

Step8:

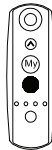

Press the down dir. button will small time intervals until the fabric is fully tensioned.

Step9:

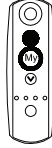

Press the My button & Up Dir. Button at the same instance for once the fabric will start to move up direction.And will stop itself at back limit position.

Step10:



Stay pressing the My button until the motor will give click movement.

Step11:



Press the programming button once. The programming is finished.

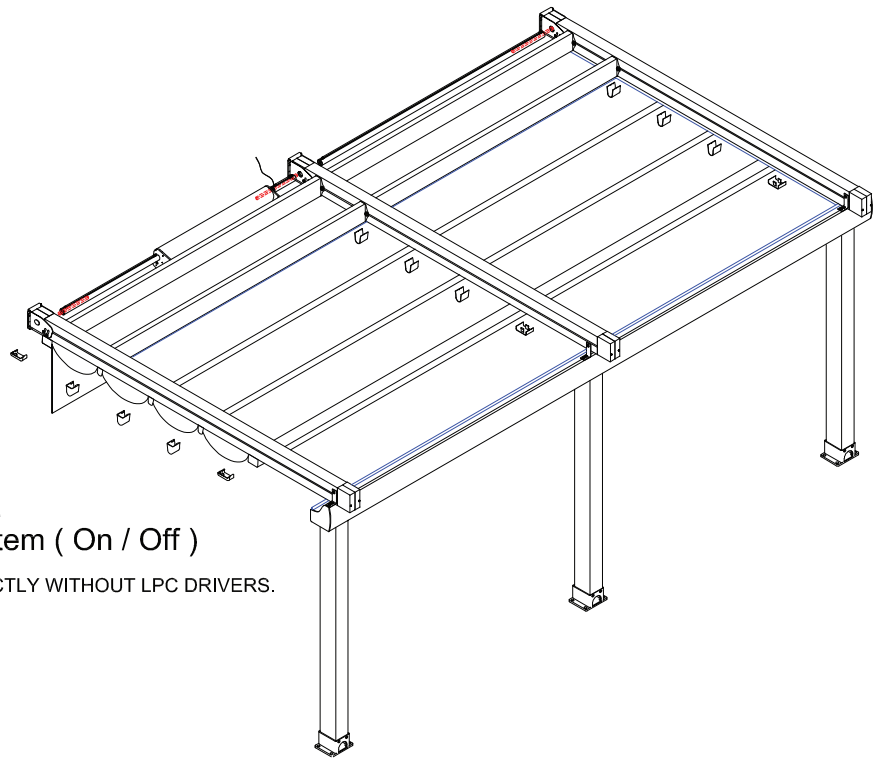

### STEP X (OPTIONAL)

#### Programming the Standart Ligthing System ( On / Off )

**⚠ FATAL ERROR FOR LEDS:DO NOT CONNECT LEDS DIRECTLY WITHOUT LPC DRIVERS.**

Step1:

#### CENTRALIS LIGHT RECEIVER RTS

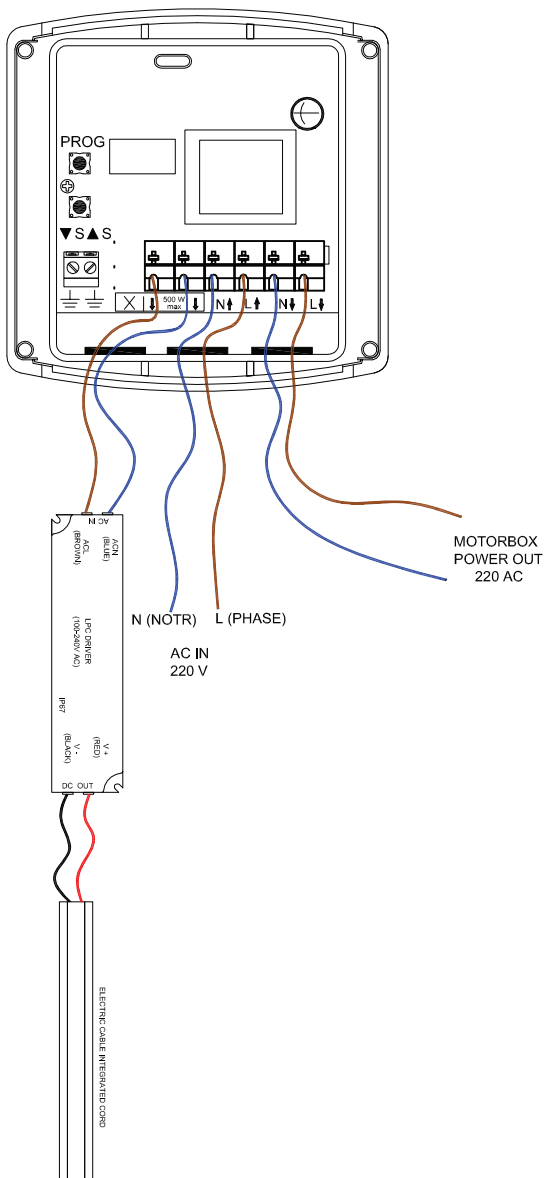

Step2:

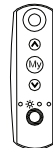

Check the channel for programming lights. Pres the channel button to select the channel 2 , make the channel 2 led light flashing.

Step3:

Press once to PROG. button which is inside the centralis light receiver unit.

Step4:



Press the programming button once. The programming is finished.



## STEP XI

Installation of top cover

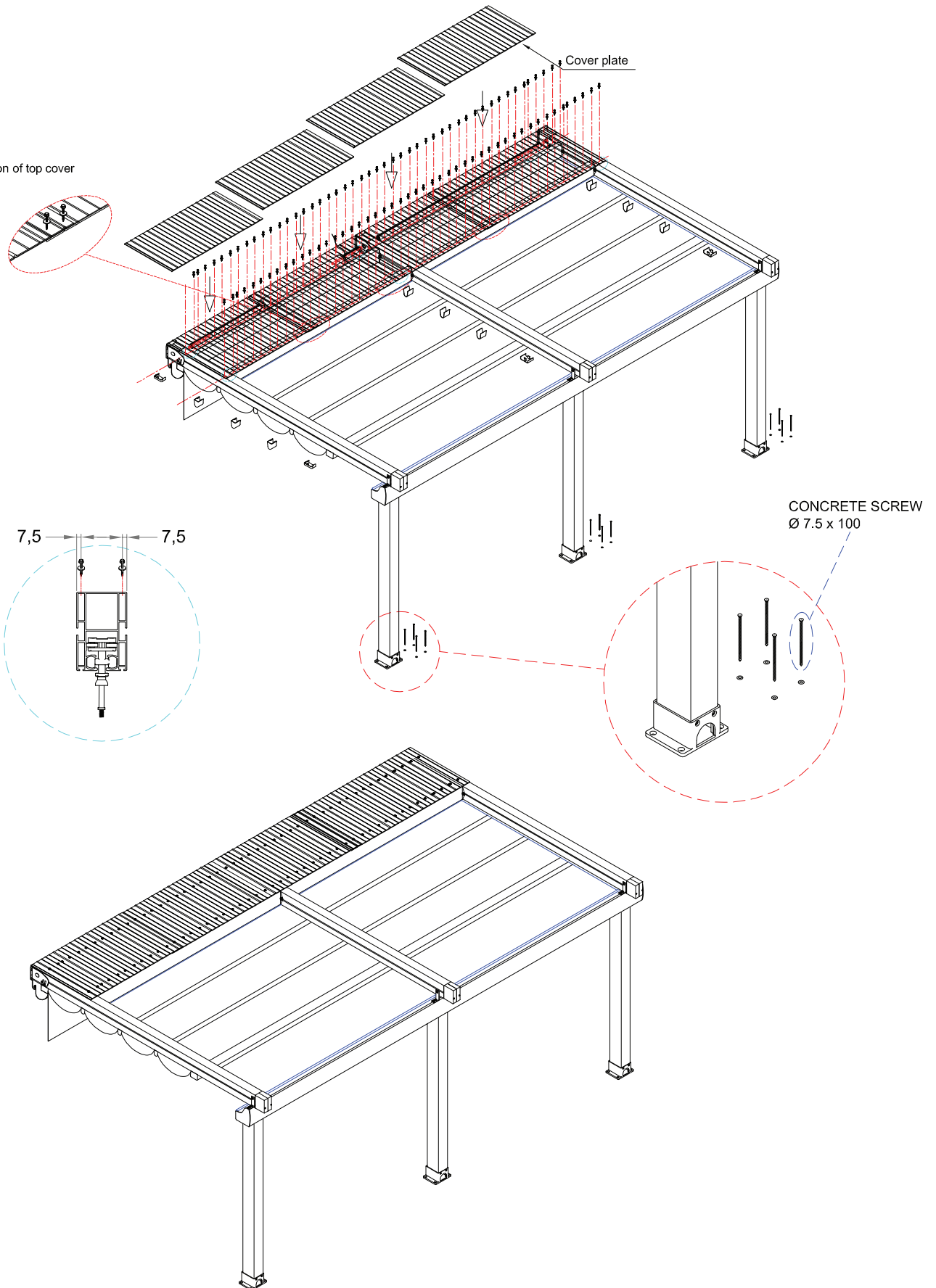

## SIDE RAFTER BAR INSTALLATION (OPTIONAL)

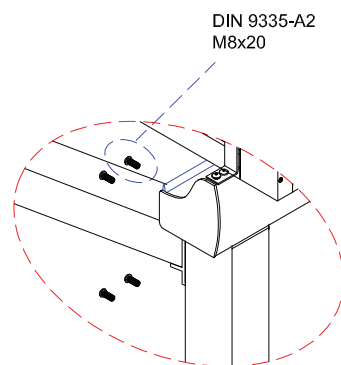
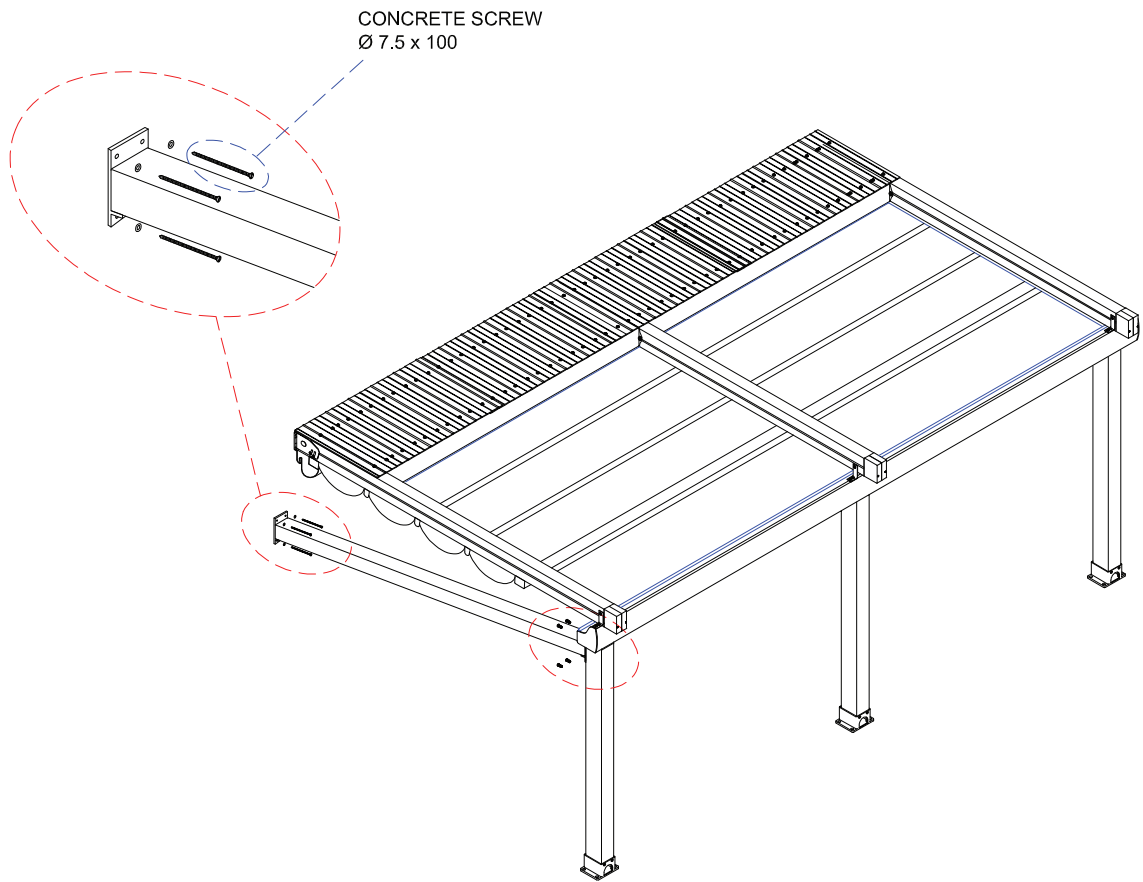

AEROFIL LOUVRE  
INSTALLATION  
(OPTIONAL)

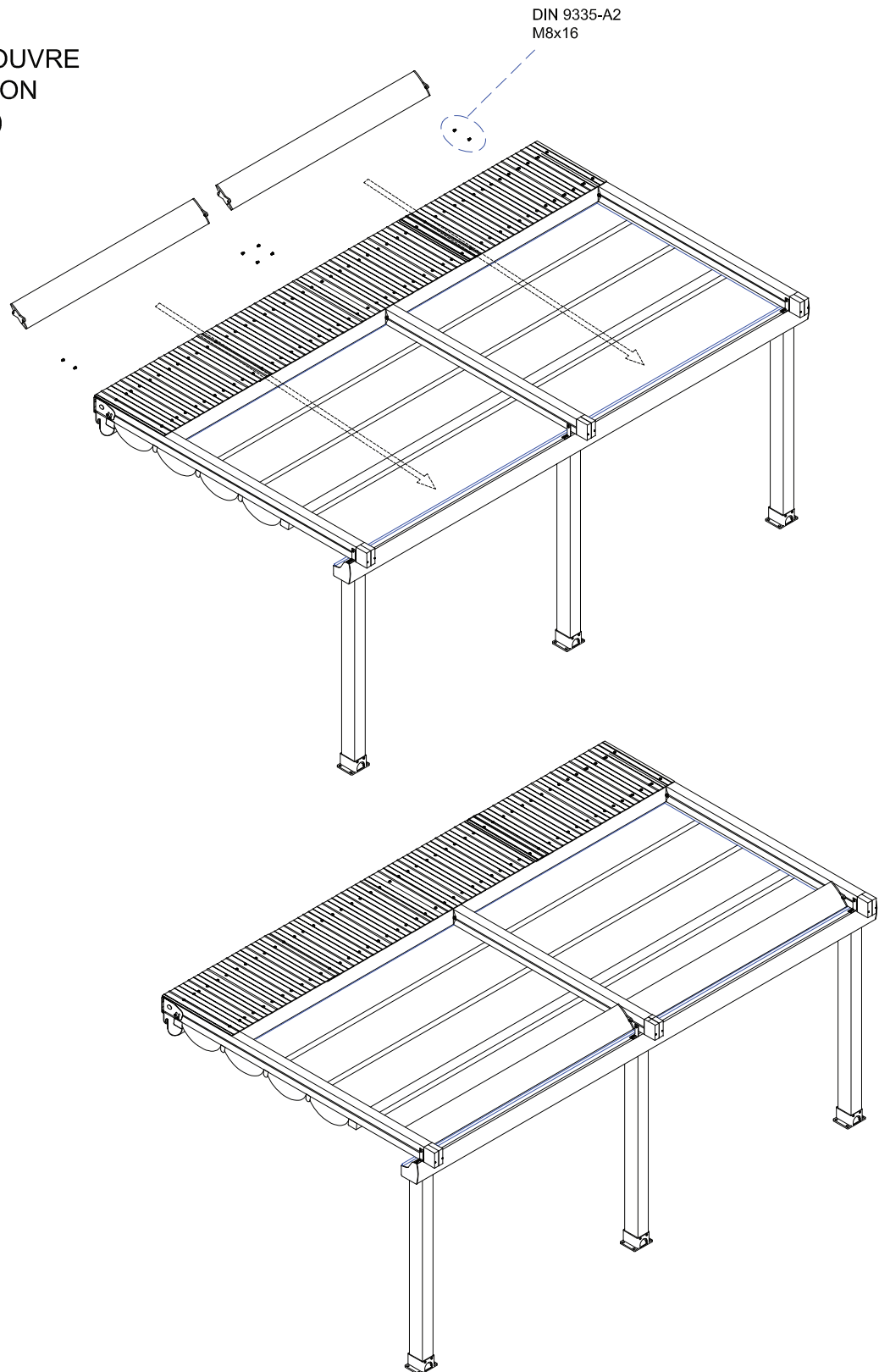

DIMMER KIT  
INSTALLATION  
(OPTIONAL)

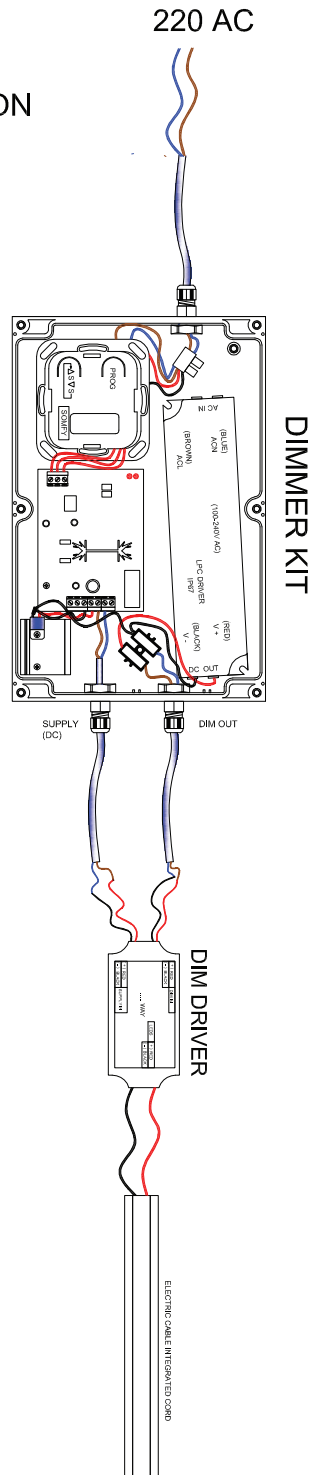

Programming Dimmer Kit

Step1:

**The Dimmer Kit Is already Programmed on Channel II on Remote Control If no;**

Step2:

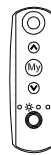

Check the channel for programming lights. Pres the channel button to select the channel 2 , make the channel 2 led light flashing.

Step3:

Press once to PROG. button which is inside the dimmer kit.

Step4:



Press the programming button once. The programming is finished.

## Double Motor Connection & Programming ( Optional )

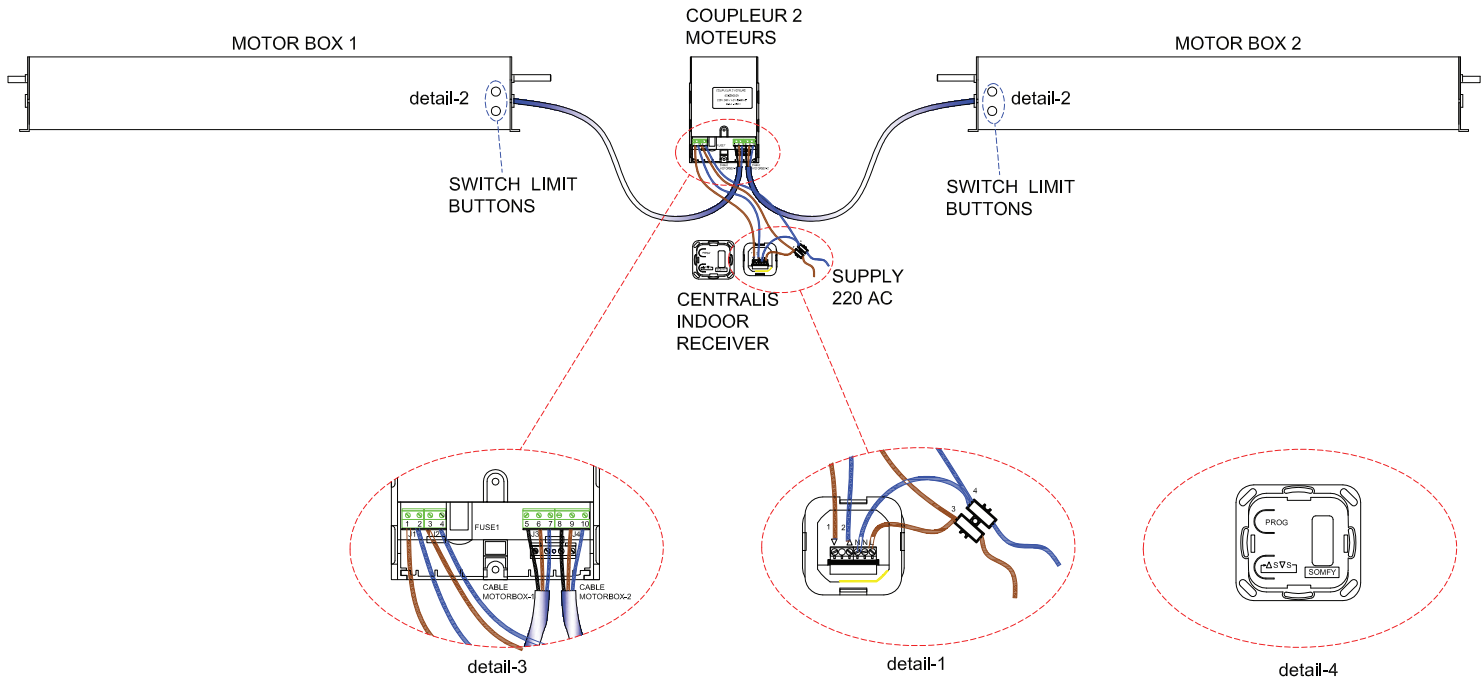

### Programming Double Motor Kit;

#### Step1:

For start be sure that motorboxes are installed like that the cable outs from motorboxes are looking to eachother. And the 220 inputs are connected together from coupleur 2 moteurs and centralis indoor. Detail-1

#### Step2:

The white&yellow buttons on motorboxes 1&2 must be pushed down position (detail-2)

#### Step3:

All programming will be done from motorbox 1 (is the motorbox which is connected to slots 5-6-7) (detail-3)

#### Step4:

From centralis indoor receiver press "S" button (detail-4) motor will start moving the system and when the system is reached to limit point push up the yellow or white button from motorbox1.

#### Step5:

Push the other "S" for the other side limit and when the system reaches the limit, bush up the other button yellow or white from motorbox1.

#### Step6:

At the end to match the remote control with centralis indoor , press the prog button on thecentralis indoor receiver and press once on the remote control which is in the back side of the remote control.

Note:To change a limit push down the yellow or white button on motorbox-1 again and move the system to new limit point and push up the button again.



*All weather protection systems!*

**RETRACTABLE**  
**AWNINGS.COM**

In the USA/Canada: (866)Get Awnings  
or (866) 438-2964

Outside the USA/Canada: (305) 628-2424

[info@retractableawnings.com](mailto:info@retractableawnings.com)